



## QUICK LOAD SERVO 105+ BARFEED

AUTOMATIC BAR FEEDER FOR  
SPINDLE LENGTH BARS FOR FIXED OR  
TRAVELING HEADSTOCK TURNING MACHINES

Diameter range:

Quick Load Servo 105+: 1/4" to 4-1/8"  
(6 mm to 105 mm)

Quick Load Servo 105+L: 3/8" to 4-1/8"  
(9.5 mm to 105 mm)

Overall barstock length: 11" to 63"\*

\*Not to exceed overall length of spindle



### PERIPHERAL VISION

For CNC machine tool peripherals, it's LNS, then all the rest



### Maximum Productivity

The Quick Load Servo 105+ is a compact, robust bar feeder with features to increase speed, productivity and versatility for bar feeding and automatic bar loading of small and medium batches. These features include quick start-ups and diameter changes, field-proven reliability, and the safety and precision of servo motor-driven bar positioning.

- Quick changeover time
- Unattended operation and reliability
- Enhanced HMI
- Fully automatic diameter adjustment
- Unmatched versatility and flexibility
- Lights-out manufacturing



### Quick Production Setup Changeovers

Start-up and diameter changing can be performed in seconds. The user-friendly, ultra-light touch screen HMI with prompting menu screens ensures the interaction between the bar feeder and the lathe, allowing the production process to run safely and efficiently.

The Quick Load Servo 105+ automatically performs all changeover adjustments by answering three simple questions when prompted by the remote control:

1. Shape?
2. Diameter?
3. Part Length?

Input any additional parameter information related to the application. Then, all changeover adjustments happen automatically.

Within the pusher diameter, your changeover is complete in seconds. The Quick Load Servo 105+ takes the information and automatically makes these adjustments:

- Bar to centerline of the lathe
- Magazine storage bar selection mechanism to bar diameter ensuring one bar is loaded at a time
- Feed and torque rates

Additional valuable features of the HMI include:

- Displays alarm descriptions
- Alarm history of operation errors and position tracking (inch/metric programming)
- Enhanced serviceability through the QR code technology populates diagnostic data and automatically generates an email to be sent to an LNS Customer Service Representative
- Forecasting tools
- A searchable list within the Parts Library program



### Automation Through Communication

The Quick Load Servo 105+ offers a "Parts Library", which is a 500 parts storage feature. The "Parts Library" allows the user to store specific parameter configurations that are unique to a machining program.

Whether you need to run the job now or at a later time, simply selecting the desired part number or name from the "Parts Library" will instantly restore the appropriate data. Saved parts programs can be saved as standard numeric or optional alphanumeric.

Enhanced with an embedded web server in the PLC allowing the bar feeder to share data with the CNC machine tool via LNS e-Connect. Ethernet interface with LNS e-Connect programmed parts in the library can be selected via CNC program.

(CNC software must support Ethernet interface)





## Large Capacity for Extended Run Time

The Quick Load Servo 105+ offers a 35" (889 mm) heavy-duty magazine capacity to stage bars for unattended operation (up to 1430 pounds) and has a clear window for viewing the remaining material. The adjustable tray permits optimum application adjustments (hex, square, etc.), including a safety switch for safely reloading. Front or rear load for optimum utilization of floor space when loading magazine tray.

- 148 bars of Ø 6 mm
- 11 bars of Ø 80 mm
- 8 bars of Ø 100 mm



## Speed, Versatility and Flexibility

In addition to fast changeovers, the Quick Load Servo 105+ offers these features:

- Access inside the bar feeder by lifting upward on the cover with window versus swinging the cover outwards
- Accommodates round, hex, square and odd-shaped material
- Feed to part length with or without turret
- Complete load cycle time of new bar stock: 15 seconds
- Complete changeover from one diameter to another: 15 seconds
- Linear ways permit feed rates up to 4,000 IPM
- Positioning accuracy is + or - .004 inches with a proper chucking device on the turning machine
- Features mechanical stop capability for end loading applications

The versatile Quick Load Servo 105+ can be converted from bar loading to high-production shaft loading within minutes and even to a one shot shaft application to load blanks down to 4 seconds.



## Faultless Unattended Operation

The highest-quality parts are used to keep you at optimum productivity, no matter what shift, no matter what day. The Quick Load Servo 105+ has the reliability to keep you running through all shifts, even unattended operation, with a menu-driven remote control, Mitsubishi servo drive and absolute encoder.

The LNS servo motor control technology provides customers accurate bar feedout control with or without turret help and prevents from striking the turret with its soft touch positioning.

\*LNS recommends "pull-to-close" dead length collet chuck or 3-jaw chuck to maintain position accuracy.



## Minimal Maintenance Downtime

Spindle liner changeover and routine maintenance on the lathe should be conducted in a timely and efficient manner to have your production back on line with minimal loss of time.

The standard Z or X-axis retraction system is easily unlocked and locked in position utilizing a foot pedal. Z or X-axis retraction configuration can be chosen at the time of installation.



## Lift Option

An optional lift designed to allow easy bar loading from a forklift or crane via a large floor level rack.

An adjustable length limiter helps position the bars before the bar feeder pick up bars one by one, lifting them up to the ramp above. X or Z-Axis retraction is fully functional and easily accessed when unit is equipped with the lift option.



# QUICK LOAD SERVO 105+ BARFEED

## TECHNICAL SPECIFICATIONS

Capacity	
Diameter	Quick Load Servo 105+: 1/4" to 4-1/8" (6 mm - 105 mm)  Quick Load Servo 105+L: 3/8" to 4-1/8" (9.5 mm - 105 mm)
Bar Length	11" to 63" (300 mm - 1600 mm) not to exceed overall length of spindle
Loading System	Gravity magazine or Lift
Loading Capacity	35" (889 mm)
Loading	Front / Rear
Shipping Weight	Quick Load Servo 105+: 1,300 lbs. Quick Load Servo 105+L: 1,350 lbs.

Applications	
Type of Headstock	Fixed / Traveling
X or Z Axis Retraction	23" (600 mm)
Changeovers	
Partial Changeover	15 seconds or less
Complete Changeover	1 minute or less
Driving Systems and Bar Support	
Motor	Servo
Drive	Notched Belt
Other	
Parts Library	500 Parts Program Storage

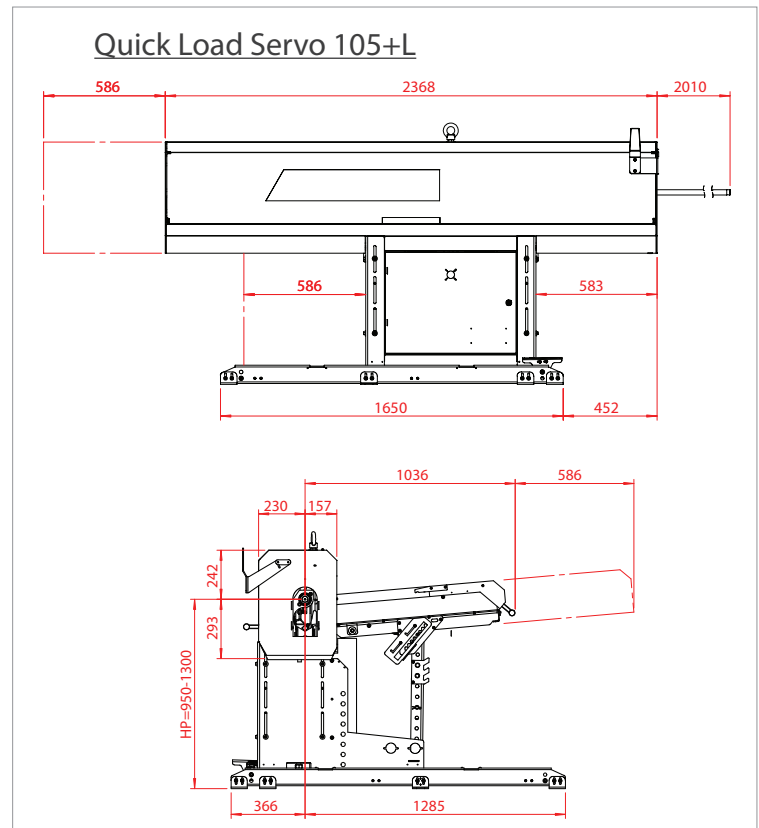
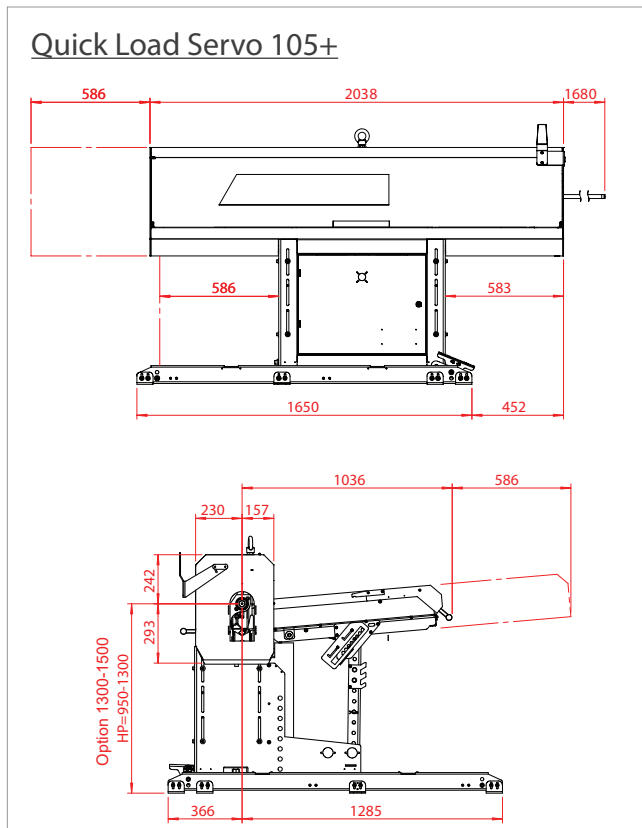

#### PERIPHERAL VISION

Peripherals, by definition, are an outer boundary. But at LNS, that boundary is where we put our focus. Because here's the secret—with LNS peripherals on your side, you can turn your attention to what you do best—making chips and making money.

That's why we do what we do. Five product categories and industry-best expertise means no company on earth can match the passion and vision we have for machine tool peripherals.



LNS North America  
4621 East Tech Drive  
Cincinnati, Ohio 45245

513-528-5674  
Allproducts-sales@LNS-northamerica.com  
www.LNS-northamerica.com