



HYDROBAR EXPRESS 332 S2+ BARFEED

AUTOMATIC MAGAZINE BAR FEEDER FOR
FIXED OR SLIDING HEADSTOCK LATHES

Diameter range: .125" to 1.25" (3 mm - 32 mm)
1.33" (34 mm) max with
bar preparation

Bar length: 48" to 12'6"



PERIPHERAL VISION

For CNC machine tool peripherals, it's *LNS*, then all the rest



Super Charge Your Productivity

The Express 332 S2+ is compact, simple with a robust design built on a heavy duty steel frame to support high performance and machined components to ensure accuracy and reliability. Stable and precise bar feeding to help you make parts quickly and accurately. Express 332 S2+ features optimized dynamic behavior through coaxial forces and efficient distribution throughout the frame ensuring minimum stress and vibrations. Efficient four points locking mechanism ensures safe secured and balance guiding of the bars in rotation. Reliability you can count on for long runs and unattended operation. Faster job changeovers with less operator involvement, faster and easier than ever before. The Express 332 S2+ is the most value-packed automatic magazine bar feed for 12' bar length available today.

Its new PLC PCD3 has a processing time ten times faster than the older generation of PLC with added connectivity (Ethernet, USB) and is ready for future communication standards with CNC of the lathe.



Increasing Your Productivity With Quick Production Setup Changeovers

Start-up and diameter changing can be performed in record time. The user friendly, ultra-light touch screen HMI with prompting menu screens ensures the interaction between the bar feeder and the lathe, and therefore the production process can be run safely and efficiently.

The Express 332 S2+ automatically makes all changeover adjustments by answering three simple questions when prompted by the remote control:

1. Shape?
2. Diameter?
3. Part Length?

Input any additional parameter information related to the application. And all changeover adjustments happen automatically.

Parts Library

For added flexibility and faster production changeovers, the "Parts Library" allows the user to store specific parameter configurations that are unique to a machining program. After all the parameters have been entered the first time, the configuration is saved as a unique number that will be associated to a specific machining program. The "Parts Library" is a standard benefit and can be used with a Standard or Ethernet interface.

Additional valuable features of the HMI include:

- Displays alarm descriptions
- Alarm history of operation errors and position tracking (inch/metric programming)
- Enhanced serviceability through the QR code technology that instantly lists diagnostic data and automatically populates an email to be sent to an LNS Customer Service Representative
- Enables monitoring of interface signals via a diagnostic timing chart
- Makes troubleshooting faster and easier by using diagnostics to access codes that quickly identify inconsistencies

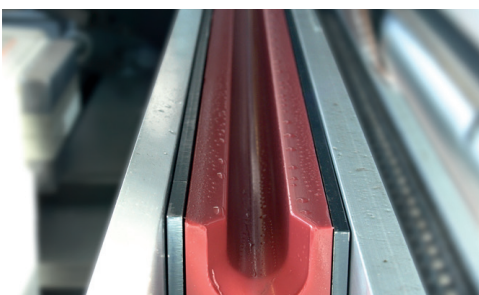

Changing The Guide Elements

The guiding elements made of extruded polyurethane are the essential elements for achieving maximum performance. They have to withstand the highest physical stresses. Designed for very fast changeovers, no manual adjustment and no tools are required.

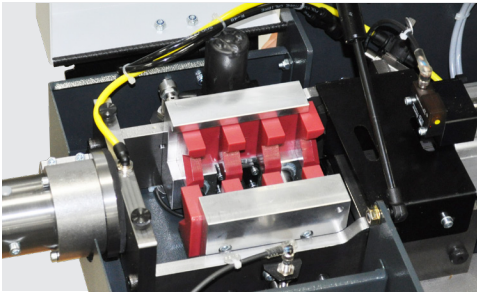

Greater Bar Stock Stability and Less Oscillation Inside the Lathe

Troublesome bar vibrations transferring to the machine cutting area can create poor machining performance and wear on tool life drastically.

The LNS patented, fully automatic “V” shaped front stabilizer uses its full 6” length to provide superior bar support from start to finish with unmatched stability. This prevents troublesome bar vibrations from transferring to the machine cutting area. And, it automatically adjusts to the bar and pusher diameters simply by memorizing the bar stock diameter and the guiding element diameter entered in the HMI (Human Machine Interface).

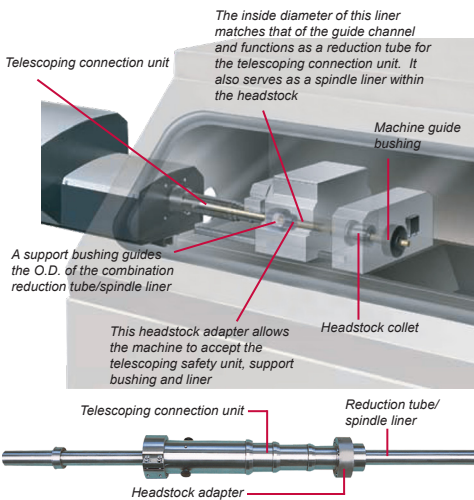

Optimum RPM & Operator Safety

The LNS Swiss safety connection eliminates the unsupported area between the bar feed and machine tool to provide greater safety and better bar stock support. It consists of a series of telescoping tubes that extend in sections to maintain a safe and continuous connection between the Hydrobar Express 332 S2 and the machine sliding headstock. This feature allows the headstock to move forward to make parts without the danger of exposed bar stock.

For added flexibility, Hydrobar Express 332 S2+ includes an assortment of reduction tubes to use within the Swiss safety connection and the lathe headstock eliminating the need of spindle reduction tubes. The inside diameters of these reduction tubes match those of the bar feed’s guiding channels providing additional support as the pusher exits the bar feeder. The result is reduced vibration and bar oscillation within a critical and traditionally under-supported area. This Hydrobar Express 332 S2+ feature improves part diameter tolerances, increases RPM, enhances surface finish, and extends tool life.



Intelligent Electronic Synchronization

Precise synchronization of the pusher assembly with bar stock during rapid movements of the sliding headstock is essential to eliminate bar buckling and unsafe disconnect from the collet fingers. Heavy mechanical components for synchronization will provide unnecessary stress on the headstock.

Combined with a Mitsubishi Servo Motor, Express 332 S2+ continuously monitors sliding headstock and bar feeding movement with the electronic synchronization system. This allows the system to actually anticipate headstock motion and precisely synchronize the movements of the pusher and lathe headstock.



Faster, Easier Routine Maintenance

Routine maintenance on the lathe should be conducted in a timely and efficient manner to have your production back on line with minimal loss of time.

A unique retract system on the Express 332 S2+ allows the bar feed to be moved back 20 inches from the machine spindle. This feature allows easier access for routine machine maintenance reducing production downtime. Simplified design for improved serviceability with easy access to all components.

Packed With Features, Simple By Design

Although the Express 332 S2+ is loaded with features you won't find anywhere else, it's designed with fewer mechanical parts for greater performance and reliability. It uses the latest advancements in electronics, servo drives and other technologies to give you the safest, most efficient and robust automatic magazine bar feed you can buy.



HYDROBAR EXPRESS 332 S2+ BARFEED

TECHNICAL SPECIFICATIONS

Capacity		
Diameter	mm	3 - 32 (34 max. with bar prep)
Bar Length (2m, 3m, 12', 4m)	mm	1000 to 2200/3200/3800/4200
Loading System	mm	Side load rack
Loading Capacity	mm	270
Loading Side		Front / Rear
Shipping Weight	lbs	1,870
Applications		
Type of Headstock		Fixed or Sliding
Remnant Length	mm	Max. 500
Headstock Synchronization		PLC / Servo-motor
Controls		Hand Held, Touch Screen with Parts Library (500 Parts)
Changeovers		
Partial changeover	min	2 within the range of guide channel
Complete changeover	min	8 or less
Driving Systems and Bar Support		
Motor		Servo
Drive		Chain
Guiding Channel		Hydrodynamic / U-Channel
ISO 100 oil	gal	21

Guiding Channel Selection Chart						
Guiding Channel Diameter	35	33	31	29	27	23
Bar Stock Diameter Range without Bar Preparation	25-32	23-30	21-28	19-26	17-24	13-20
Bar Stock Diameter Range with Bar Preparation	25-34	23-32	21-30	19-28	17-26	13-22

Guiding Channel Selection Chart						
Guiding Channel Diameter	21	19	17	14	11	8
Bar Stock Diameter Range without Bar Preparation	11-18	8-16	7-14	4-10	3-8	3-5
Bar Stock Diameter Range with Bar Preparation	11-20	8-18	7-16	4-12	3-10	3-7

Barstock Straightness Specifications and Performance
 For optimum rotational performance speeds, bar stock straightness needs to be .020" per 3.25 feet, non accumulative. Bar stock out of this tolerance will not run at optimum RPM. Other factors such as material type (brass, copper, bronze and other malleable materials), clamping efficiency of the machine workholding, alignment of the bar feed, oil type, bar preparation and spindle liners will affect optimum RPM capability of the system.

A	7.5" (191mm)	J	5.8" (148mm)
B	7" (180mm)	K	3.4" (87mm)
C	8.6" (218mm)	L	3.2" (82mm)
D	12.8" (326mm)	M	7.6" (195mm)
E	18.9" (480mm)	N	19.2" (488mm)
F	12.2" (310mm)	O	14.5" (370mm)
G	18.9" (480mm)	P	6.5" (165mm)
H	9.4" (240mm)	Q	9" (228mm)
I	6" (154mm)	R	HP 35.4"-49" (900-1250mm)

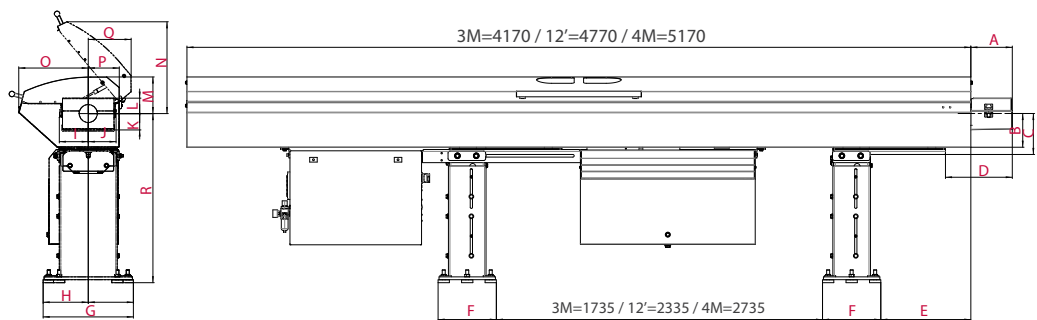

PERIPHERAL VISION

Peripherals, by definition, are an outer boundary. But at LNS, that boundary is where we put our focus. Because here's the secret—with LNS peripherals on your side, you can turn your attention to what you do best—making chips and making money.

That's why we do what we do. Five product categories and industry-best expertise means no company on earth can match the passion and vision we have for machine tool peripherals.



LNS North America
 4621 East Tech Drive
 Cincinnati, Ohio 45245

513-528-5674
 Allproducts-sales@LNS-northamerica.com
 www.LNS-northamerica.com